

3022BHE

BOTTOM HEMMING UNIT

- » From lockstitch to chainstitch and vice-versa with conversion kit (supplied)
- » Now the change takes only 20/25 minutes!

- » Electronic regulation of stitch length

FRONT AND REVERSE FOLDERS
(BOTH SUPPLIED):

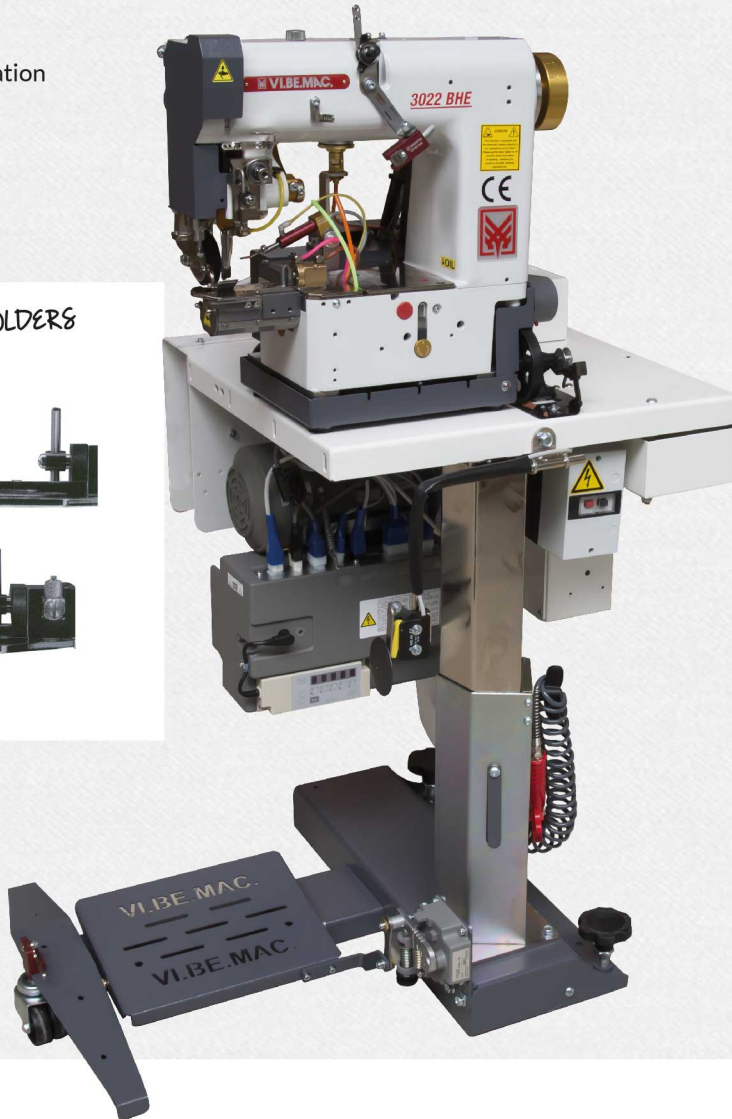
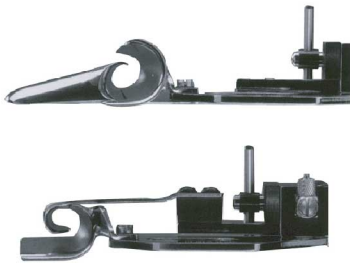

Vi.Be.Mac. is proud to present another achievement in its range of machines, entirely designed and manufactured in its own factory. The 3022 BHE represents the market's solution to trouser hemline problems: accurate, productive and characterised by the flexibility that has become the hallmark of all Vi.Be.Mac. products.

TECHNICAL FEATURES:

The design of the sewing head allows to convert the machine from lock stitch to chain stitch and vice-versa, in case of changes of style, no need to purchase a new machine. With the conversion kit supplied, in about 20/25 minutes you will be ready to start sewing your new style.

It is possible to work outside or inside out, replacing the folder, whose width of the hem goes from 9 to 30 mm with a standard folder, up to 42 mm with an optional folder sold separately.

The stitch length setting is electronic thus easier, faster and adjustable in a matter of few seconds. The puller system, a Vi.Be.Mac. invention, is composed by a lower roller feeder with an extremely powerful, patented upper puller, that easily handles the more delicate operations like crossovers or lap felling, especially with heavy fabrics.

Complete the picture a king size capacity rotating hook, with decreased loss of time due to the need to change the bobbin and the smallest cylinder arm in the market that permit to work easily even kids and ladies garments.

EQUIPPED WITH:

- » safety chain condensed stitch, conversion kit, standard and reverse folder
- » two needle plates with thread trimmer (for chainstitch and lockstitch)
- » FLEXIBLE: this unique unit makes it possible to change from light to heavy fabrics without any alteration to mechanical components or electronic adjustments
- » a thread-cutting system handled by the XCG MFY 2005 panel
- » the pneumatic system for the toggle-joint opening of the guide can be selected by the operator in two different modes: manual or automatic, with the foot lifting at the same time
- » pneumatic foot lift
- » lubrication system
- » quick change of stitch length: less then one minute
- » new design of the stand, with a special cylinder inside the column than makes machine floating for easy adjustment in height

SPECIFICATIONS:

- * Max Sewing Speed: 4000 rpm Chainstitch, 3500 rpm Lockstitch
- * Standard Stitch Length: from 0,9 to 9 mm
- * Hem Width: from 9 to 30 mm (optional 42 mm)
- * Sewing Head: Vi.Be.Mac.
- * Power Supply Voltage: 220 V 50/60 Hz
- * Sewing Machine Motor: Mitsubishi XCG 554 20Y - 550W
- * Control Box: XCG MFY 2005
- * Air consumption: 2 L/min

SMALLEST CYLINDER ARM
IN THE MARKET!

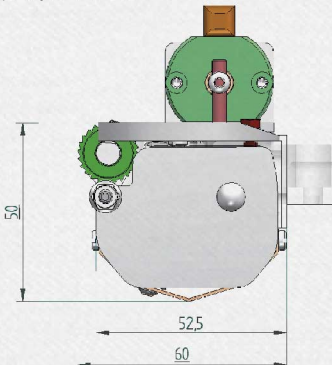

BOTTOM HEMLING

